

NUMERACY

YEAR

5

2012

0:50

Time available for students to
complete test: 50 minutes

Use 2B or HB
pencil **only**



YEAR 5 NUMERACY

1

Marie had 12 biscuits. She then ate 2 and gave 3 to a friend.

How many biscuits does Marie have left?

7

8

9

17

2

Which picture shows a reflection over the dotted line?

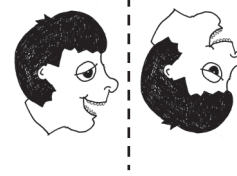
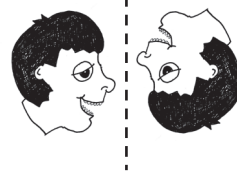
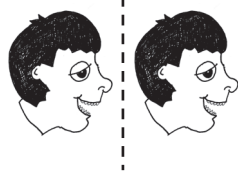
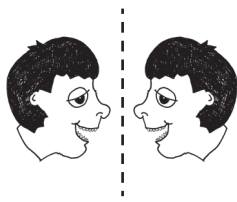

3

Bench B



Room 1	Room 2	Room 3	Room 4	Room 5
Room 10	Room 9	Room 8	Room 7	Room 6

Bench A



Bench C



Bench D



Alice walks out of the door of Room 7 and goes to the nearest bench.

Which bench does she go to?

Bench A

Bench B

Bench C

Bench D

YEAR 5 NUMERACY

4

This table shows the three favourite subjects of four students.

	English	Maths	Art	Sport	Science	Music
Emma	✓			✓		✓
Hugh			✓		✓	✓
Sami		✓			✓	✓
Jake			✓	✓	✓	

Which student chose Science but **not** Art?

Emma

Hugh

Sami

Jake

5

Steven left for school at 8:45 am. He got to school at 9:06 am.

How long did it take Steven to get to school?

15 minutes

21 minutes

51 minutes

61 minutes

6

$47 + 16 = ?$

53

62

63

513

7

Freya makes this tower from identical blocks.

Which of these shows how to find the total number of blocks?

3×10

6×10

$3 + 3 + 10$

$5 \times 3 + 3$

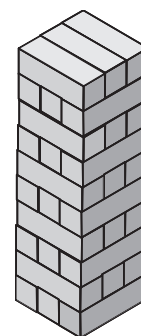

YEAR 5 NUMERACY

8 How many odd numbers are between 20 and 32?

5

6

7

11

9 Look at this picture of two cylinders.

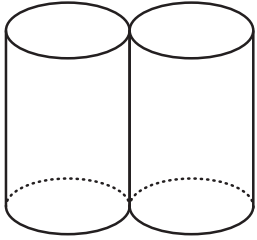

Which of these shows the top view?

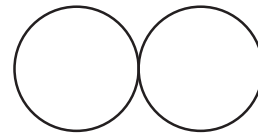
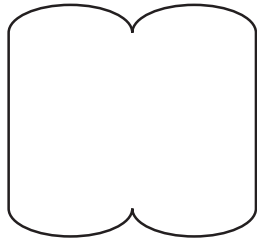

10 Which of these units could be used to measure the **mass** of a dog?

- litres
- kilograms
- seconds
- metres

YEAR 5 NUMERACY

11

Alan has 3 clips.
The sizes of the clips are small, medium and large.

The picture shows the lengths of the small and large clips.

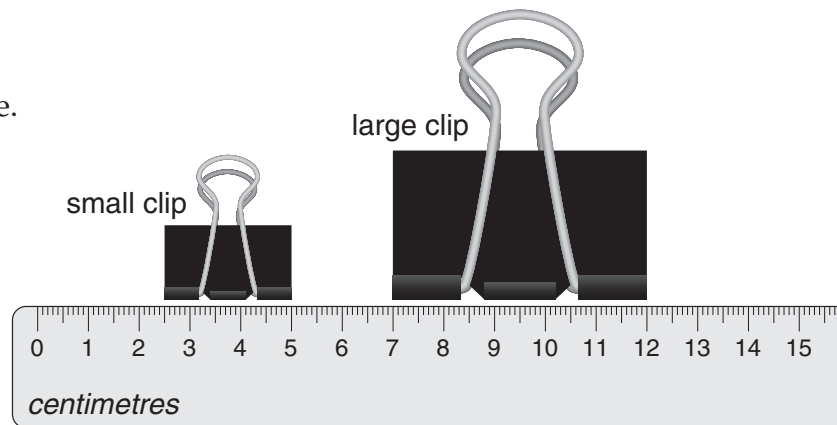

What could the length of the medium clip be?

2 centimetres

4 centimetres

6 centimetres

8 centimetres

12

Which of these shapes has one line of symmetry?

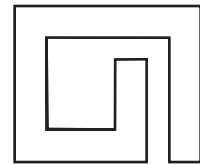
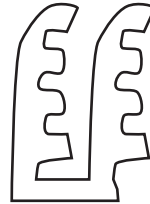
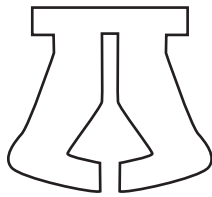

13

A Year 5 class was asked a question in a survey.
The first six answers to the question were:

10 11 10 9 10 11

Which one of these questions could have been asked?

- Are you a boy or a girl?
- How many centimetres tall are you?
- What colour is your hair?
- How many years old are you?

YEAR 5 NUMERACY

14

In Year 4 there are 13 more girls than boys.
Trent knows there are 49 girls.

How can Trent work out the number of boys in Year 4?

- add 49 to 13
- subtract 13 from 49
- multiply 13 by 49
- divide 49 by 13

15

Megan tosses a normal coin four times.
It lands heads up each time.
She tosses it a fifth time.

Which of the following is true?

- It is more likely to land heads up than tails up.
- It is certain to land tails up.
- It has an equal chance of landing heads up or tails up.
- It is more likely to land tails up than heads up.

16

Kate has this much money.



She buys an apple for 75 cents.

How much money does Kate have left?

25 cents

35 cents

40 cents

45 cents

YEAR 5 NUMERACY

17

These shapes are the five faces of a 3D object.



What is the name of the object?

- cone
- square pyramid
- triangular pyramid
- triangular prism

18

Dean had some money in his pocket.
He spent \$1.25 and then had \$1.95 left.

How much money did Dean start with?

\$.

19

Some friends try to throw a ball into a hoop.
They each throw 10 times with their left hand and 10 times with their right hand.
Here are the results.

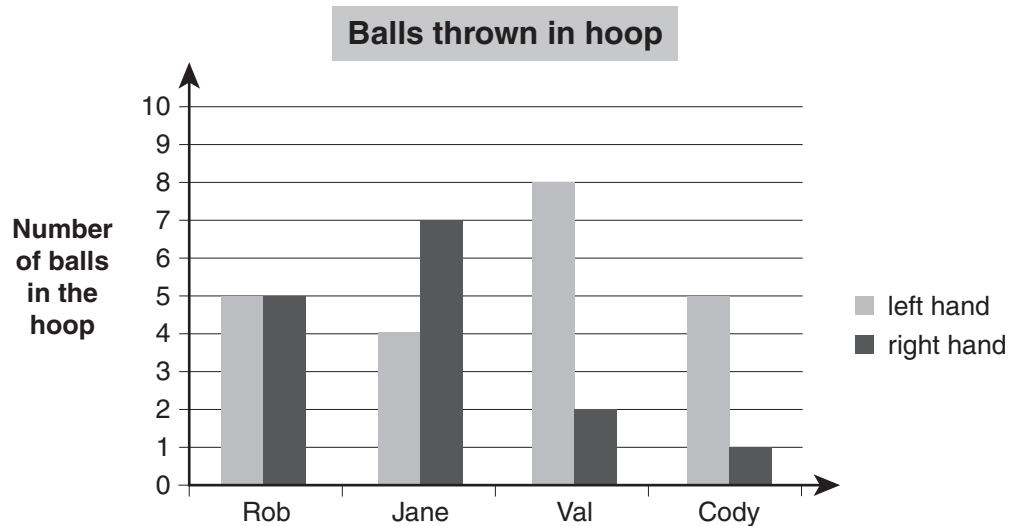

Who threw the most balls into the hoop?

- Rob Jane Val Cody
-

YEAR 5 NUMERACY

20

Fran is cutting tags from a sheet of cardboard.
Each tag looks like this.

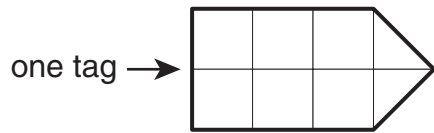

Fran throws away any pieces that are not whole tags.

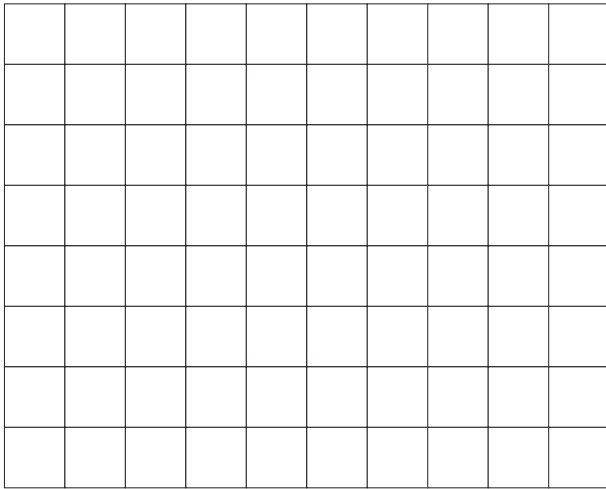

What is the **greatest** number of tags that Fran can cut from this sheet?

21

Sandy drew a shape.
It has three sides equal in length and only one side that is longer.

Which of these could be Sandy's shape?

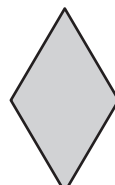
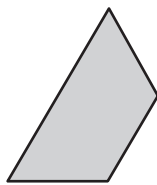
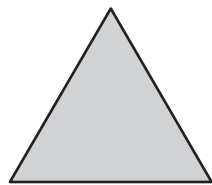
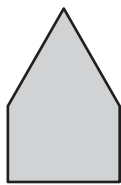

YEAR 5 NUMERACY

22

Lydia starts with a number.
She doubles it and then subtracts 4 to get an answer of 8.

What number did Lydia start with?

6

8

12

24

23

The picture shows three floors of a hotel.

The rooms are numbered using the same method on each floor.

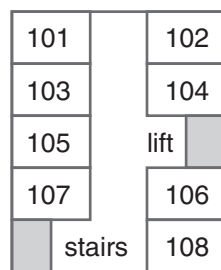

Floor 1

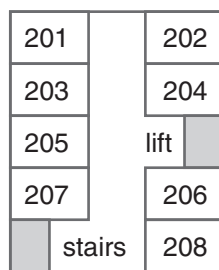

Floor 2

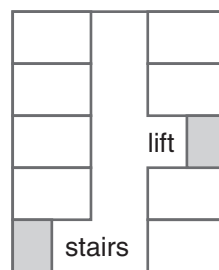

Floor 3

North



Jack's room is on Floor 3 in the south-east corner.

What is Jack's room number?

301

302

307

308

24

Lucas put three identical tiles together at their edges.

He drew around the outside to make this new shape.

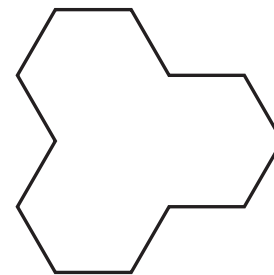

Which of these could have been the shape of his tiles?

triangles

trapeziums

pentagons

hexagons

YEAR 5 NUMERACY

25

Which of these angles is greater than 90° but less than 180° ?

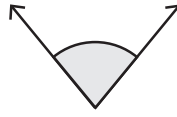

26

Each new number in this pattern is made by adding together the two numbers before it.

?, 16, 23, 39

What is the first number in the pattern?

27

About what fraction of the large square is shaded grey?

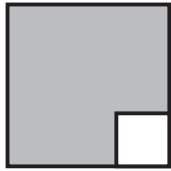

$\frac{1}{3}$



$\frac{1}{9}$



$\frac{2}{3}$



$\frac{8}{9}$



28

Jane got out of bed at 7:30 am.

She went back to bed $13\frac{1}{2}$ hours later.

At what time did she go back to bed?

8:30 pm



9:00 pm



10:30 pm



11:00 pm



YEAR 5 NUMERACY

29

Dave is making a pattern of tiles.

At each stage, tiles are added to edges that don't already have a tile on them as shown.

Stage 1
1 tile



Stage 2
4 tiles



Stage 3
10 tiles



Stage 4
19 tiles

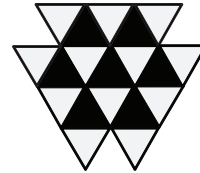

What is the total number of tiles needed for Stage 5?

22



28



31



33



30

Kim has an ink stamp that makes this shape.



Kim makes each of these designs by stamping the shape four times.

Which of Kim's designs has **only two** lines of symmetry?

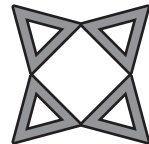
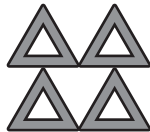

YEAR 5 NUMERACY

31

Which letter shows where 50 would be on this number line?

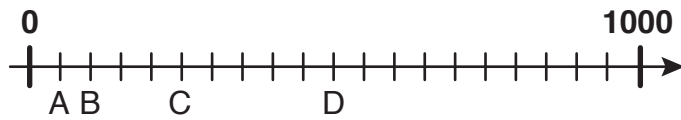

- A
- B
- C
- D

32

Rosa and Hank both read books with 50 pages.
This chart shows the total number of pages they read.

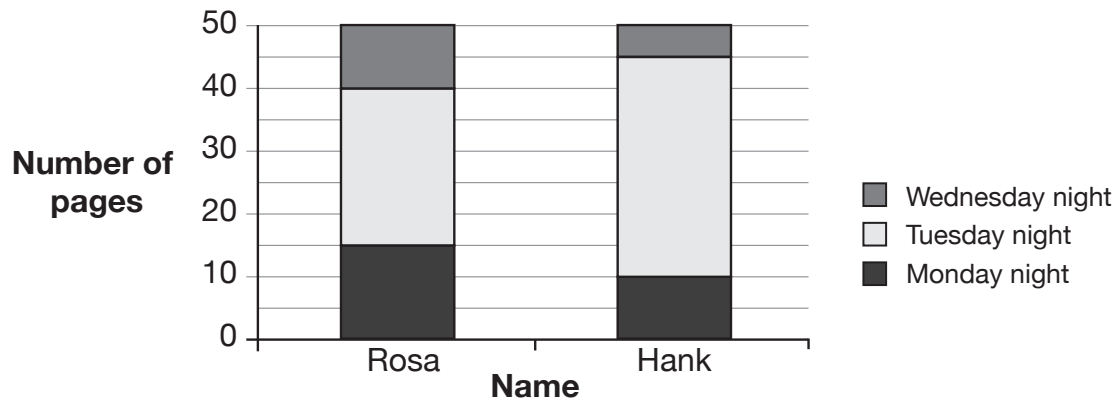

How many **more** pages did Hank read than Rosa on Tuesday night?

33

Sue has these four number cards.



What is the closest number to 3000 that Sue can make using all four cards?

YEAR 5 NUMERACY

34

A teacher has 9 packets of crayons.
There are 6 crayons in each small packet.
There are 10 crayons in each large packet.
The teacher has 3 small packets.

How many crayons does he have altogether?

35

Cody, Liam and Molly have 60 stickers in total.
Cody has half as many stickers as Liam.
Molly has three times as many stickers as Cody.

How many stickers does Cody have?

36

Brendan made a special dice from this net.

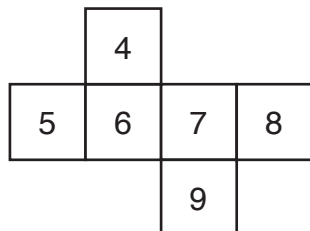

After he rolled the dice, he added the numbers on the bottom and the top together.

What is the greatest possible total Brendan could get?

YEAR 5 NUMERACY

37

There are 600 vehicles in a car park.

One-third of them are trucks. The rest are cars. One-quarter of the cars are white.

How many white cars are in the car park?

38

Tilly puts some forks and spoons end to end.

3 forks make the same length as 5 spoons.

Each fork is 15 centimetres long.

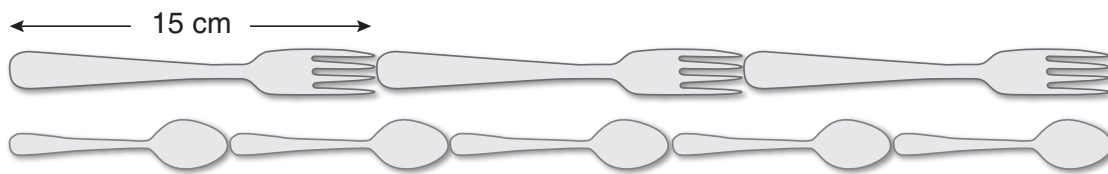

How many centimetres long is each spoon?

 centimetres

39

Jo packs small boxes into a larger box.

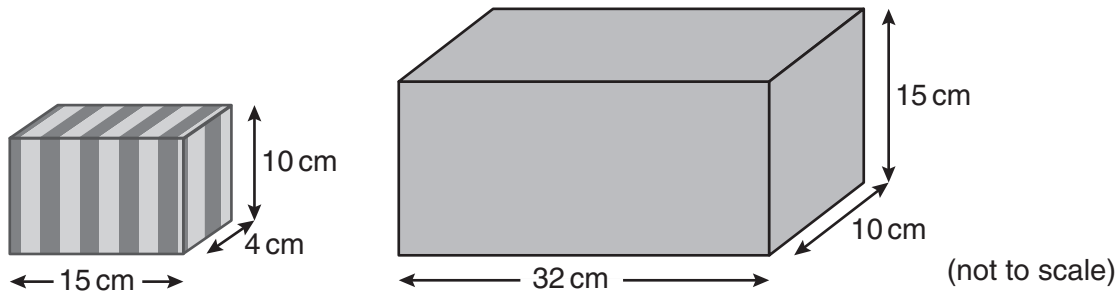

What is the **greatest** number of the small boxes that will fit into the large box?

YEAR 5 NUMERACY

40

Yusuf copied a picture of a car onto a grid.

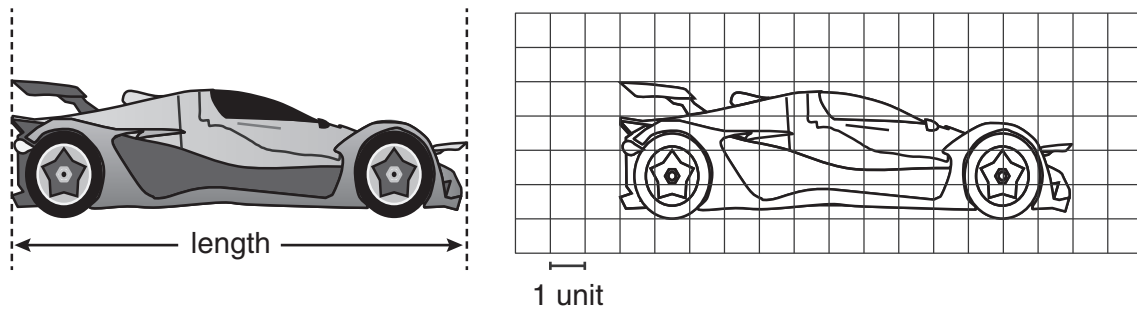

The real car has a length of 390 centimetres.

How many centimetres of the real car does one unit on the grid represent?

centimetres

STOP – END OF TEST

YEAR 5 NUMERACY

PRACTICE QUESTIONS

P1 How many apples are shown?

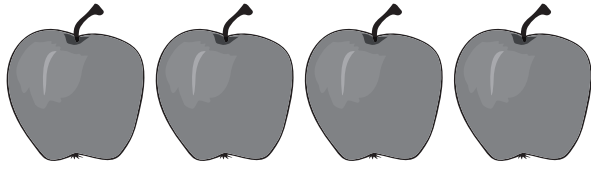

3

4

5

6

P2 Write a number in the box to make this number sentence correct.

$$6 + 4 = \boxed{}$$