

# NUMERACY

## CALCULATOR ALLOWED

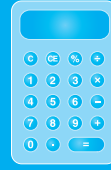

YEAR  
**9**  
2015



### SESSION 1

**40 min**

Time available for students to  
complete test: 40 minutes

Use 2B or HB  
pencil **only**





1

Brian made this 3D object using 48 small cubes.

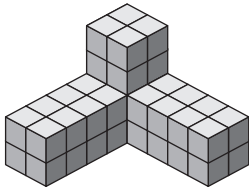

Which of these has a volume half that of Brian's object?

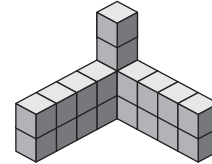
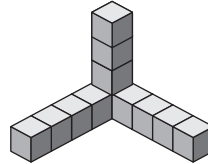
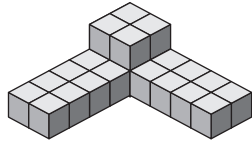
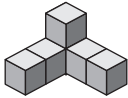

2

Which of these can be measured in litres?

area



mass



volume



length



3

This is Donna's left shoe.

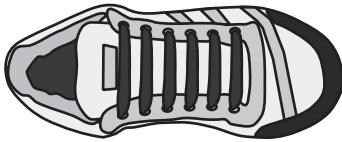

Donna's right shoe is a mirror image of her left shoe.

Which of these is Donna's right shoe?





4

$$y = 2x^2 - 8$$

What is the value of  $y$  when  $x = 2.2$ ?

- 6.32

0.8

1.68

11.36

5

The speed of sound at sea level is 340 metres per second.

What is the speed of sound in metres per minute?

34 000

20 400

5.7

3.4

6

What is the value of  $\frac{63.4 + 28.24}{9.2 \times 1.6}$  rounded to one decimal place?

6.2

15.9

24.5

68.3

7

A cardboard box is in the shape of a cube.

It is filled with identical small cubes of the size shown.

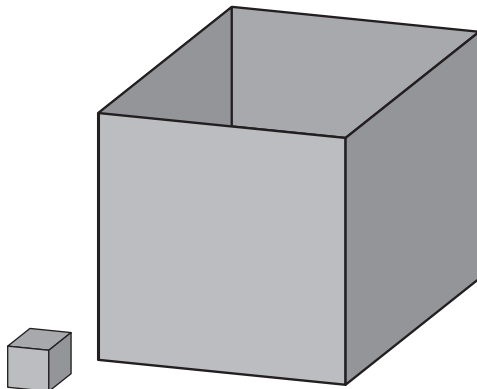

Which of these is the closest estimate for the number of cubes that would fill the box?

25

40

200

800



8

One billion is one thousand million.

Which of the following is 70 billion?

$7 \times 10^{13}$

$7 \times 10^{10}$

$7 \times 10^7$

$7 \times 10^4$

9

There are 12 apples and 7 pears in a bowl.

About what percentage of the fruit in the bowl is pears?

7%

37%

58%

63%

10

Which one of these has the same value as  $20^2$ ?

$40^2 \div 4$

$2 \times 2 \times 5 \times 2 \times 5$

$4 \times 5^2$

$2 \times 10 \times 10$

11

A concert starts at 10:28 am and runs for 124 minutes.

What time does it finish?

11:52 am

11:52 pm

12:32 am

12:32 pm

12

The diagram shows an isosceles triangle.

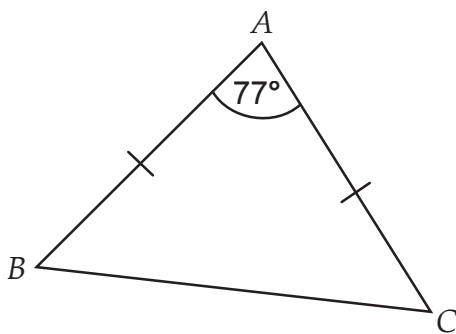

What is the size of the angle  $\angle ABC$ ?

$38.5^\circ$

$45^\circ$

$51.5^\circ$

$60^\circ$



13

The petrol gauge in Lyn's car showed that she had used half of the petrol in the tank. She then spent \$42 filling up her tank at a cost of \$1.35 per litre.

Approximately how much petrol can Lyn's petrol tank hold when it is full?

31 litres

57 litres

62 litres

84 litres

14

Teagan and Caleb collected money for charity over a month.

If Caleb had collected \$10 more, he would have collected exactly twice as much as Teagan.

Which row of the table shows how much money they could have collected?

	Teagan	Caleb
<input type="radio"/>	\$15	\$30
<input type="radio"/>	\$20	\$50
<input type="radio"/>	\$25	\$40
<input type="radio"/>	\$30	\$80

15

Continent	Number of cars produced
Africa	636 519
Asia/Oceania	45 800 878
Europe	19 726 405
North America	21 136 313
South America	4 288 654

How many **more** cars were produced in North and South America than in Europe and Africa?



16

Mia drew a shape. It had only one pair of parallel sides and only one internal reflex angle.

Which of these could be Mia's shape?

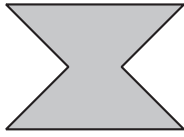

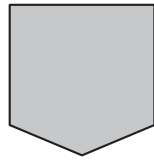

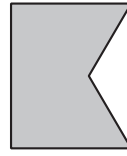

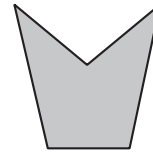

17

Simon is facing west. He turns  $135^\circ$  clockwise.

Simon then turns anticlockwise until he faces east.

By how many degrees did Simon turn anticlockwise?

$45^\circ$

$180^\circ$

$225^\circ$

$315^\circ$

18

The equation  $2y + 1 = x$  is rearranged to have  $y$  as the subject.

Which of these correctly gives  $y$  as the subject?

$$y = \frac{x-1}{2}$$

$$y = \frac{x+1}{2}$$

$$y = 2x - 1$$

$$y = 2x + 1$$

19

Which of the following has the same value as  $13^{-13}$ ?

$$-13^{-13}$$

$$13 \times (-13)$$

$$\frac{1}{-13^{13}}$$

$$\frac{1}{13^{13}}$$

20

The rule for calculating the price to deliver a parcel of mass  $m$  kg is  
price (\$) =  $7 + 3.5m$ .

What is the mass, in kg, of a parcel with a delivery price of \$70?

13

18

22

27

252



21

David drew this diagram of a frog's skeleton.

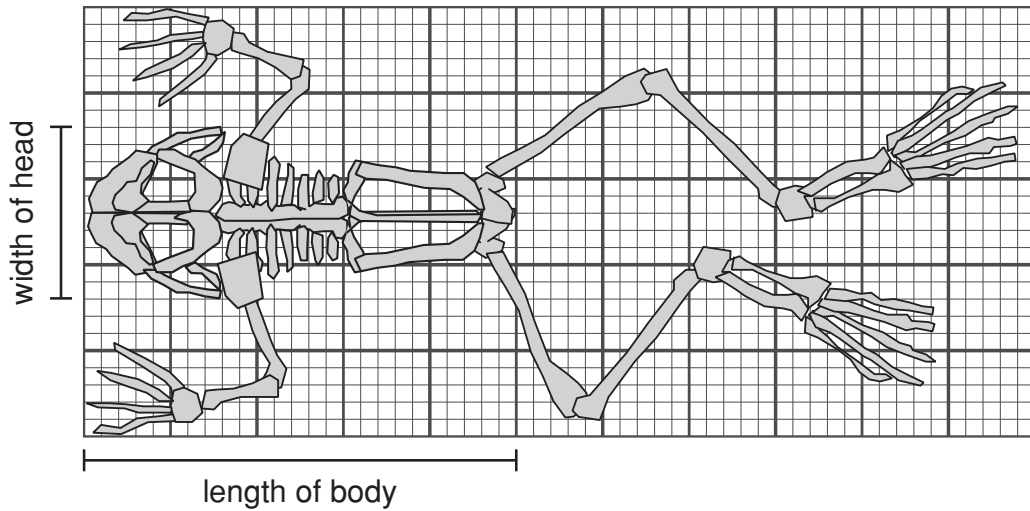

The actual length of the frog's body is 100 millimetres.

What is the actual width of the frog's head?

millimetres

22

This sand timer contains 595 g of sand.

It takes half an hour for all of the sand to flow through the timer.

Each millilitre of sand weighs 1.6 g.



How many millilitres of sand flow through the timer per minute?

12.4

19.8

31.7

743.8



23

Sarah was collecting money for charity.

By Sunday night she had collected 55% of her target amount.

On Monday she collected another \$70, which meant she had now collected 75% of her target amount.

What was Sarah's target amount?

\$

24

Kim uses sticks to make a pattern of squares.

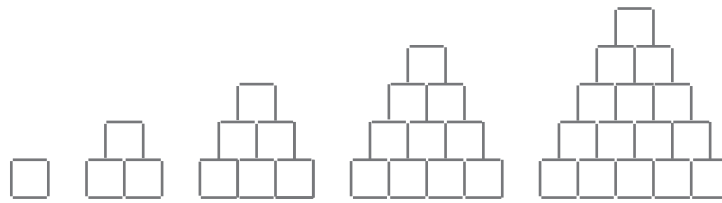

<b>Number of squares</b>	1	3	6	10	15
<b>Number of sticks</b>	4	10	18	28	40

When a shape consists of 28 squares, how many sticks will the shape have?

25

The total length of all edges of a cube is 156 cm.

What is the volume of the cube?

cm<sup>3</sup>





26

Which statement is always true?

- The opposite angles of a kite are equal in size.
- The opposite sides of a trapezium are equal in length.
- The diagonals of a parallelogram are equal in length.
- The angles formed by the intersection of the diagonals of a rhombus are equal in size.

27

A new power drill was on sale with 15% discount.

As a regular customer, Peter received a further 10% on the already discounted price.

What was the overall percentage discount Peter received?

- |                       |                       |                       |                       |                       |
|-----------------------|-----------------------|-----------------------|-----------------------|-----------------------|
| 1.5%                  | 12.5%                 | 16.5%                 | 23.5%                 | 25%                   |
| <input type="radio"/> | <input type="radio"/> | <input type="radio"/> | <input type="radio"/> | <input type="radio"/> |

28

The edges of Greg's swimming pool form a 10 m × 4 m rectangle.

He tiled around the edges of his pool using one row of 400 mm × 400 mm tiles.

Greg put one star tile at each corner of the pool as shown.

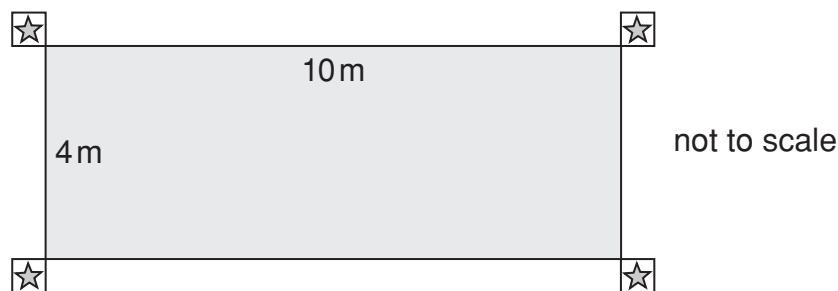

He used an equal number of black and white tiles to finish off the edges.

The table shows the price of each kind of tile.

<b>Tile</b>			
<b>Price</b>	\$15	\$10	\$7

What was the total cost of the tiles he used?

\$



29

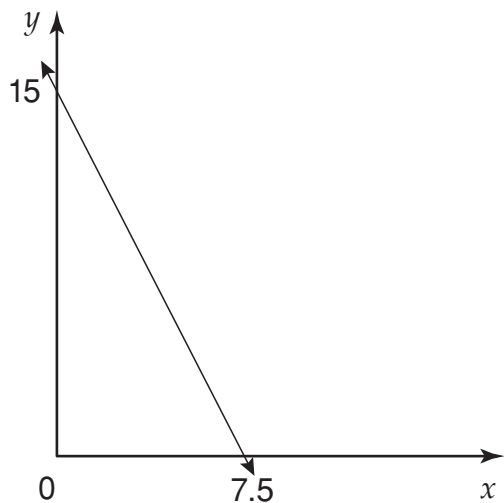

Which of these equations represents the line in the graph?

$y = 15 - 2x$

$y = 15 + 7.5x$

$y = 15 - 7.5x$

$y = 15 + 2x$

30

In the diagram  $AB$  is a straight line.

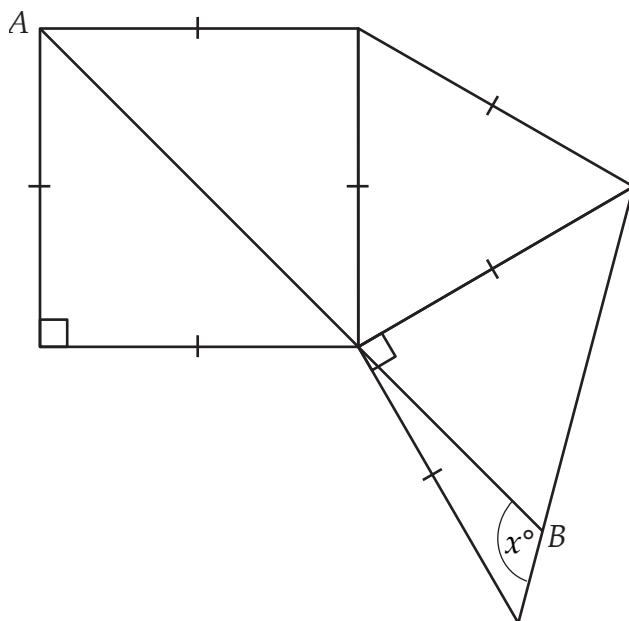

What is the size of the angle marked  $x^\circ$  ?

degrees



31

The product of three different whole numbers is 60.

What is the largest possible sum of the three numbers?

32

This shape was formed by removing a sector from a circle of radius 9 cm.

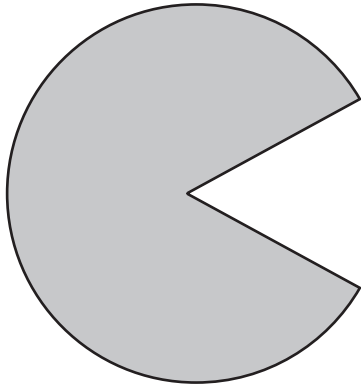

The area of the sector was  $\frac{1}{6}$  of the area of the circle.

What is the perimeter of the shape, to the nearest centimetre?

 cm

**STOP – END OF TEST**

**Do not turn this page.**